



Installation Instructions FLST/FXST Softail Adjustable Lowering Kit

1984 to 1988 Models

WARNINGS & ALERTS

- This kit is designed for Harley-Davidson OEM shocks.
- Adjustable +1/2" to -2.00" lower - recommended maximum drop of 1-1/4".
- The operator must use extreme caution when operating a modified motorcycle, particularly while familiarizing himself with its altered handling characteristics.
- Check your motorcycle for proper parking lean angle AFTER installation of this kit. Your sidestand may require modification.
- Follow all instructions to achieve proper clearance.
- Enclosed sticker must be applied to a visible area of any motorcycle on which the Burly Brand lowering kit has been installed in order to inform potential riders that the bike has been modified.

TOOLS REQUIRED

- Hydraulic Press OR Progressive Suspension tool #32-5507
- Vice
- Jack and/or Stand
- Wrenches - 9/16", 5/8", 3/4, 1"
- Pick
- ft. / lb. Torque wrench & 3/4" socket
- Red thread-locking agent (Loctite®)
- Blue Thread locking agent (Loctite®)
- Anti-seize compound
- Moly-disulfide or other heavy grease

LIMITED GUARANTEE

We continually inspect and try to improve our products. All parts have been inspected prior to packaging, and our guarantee is limited to replacement of defective parts. This guarantee is in lieu of all guarantees or warranties implied or expressed. Because we cannot control the application of our products, buyer assumes risks for any and all damage caused by himself or third party, by virtue of failure of these parts. We make no warranty as to products distributed by us, expressed or implied, including without limitation any warranties or merchant ability and fitness for a particular purpose. We will however, pass on all warranties made by the manufacturer, who has sole responsibility for performing such warranties. The manufacturer shall solely be responsible for any damage to person or property arising from design, manufacturing and testing of all products, and we accept no liability for such damages. We shall not be liable for indirect or consequential damages.

PARTS INCLUDED

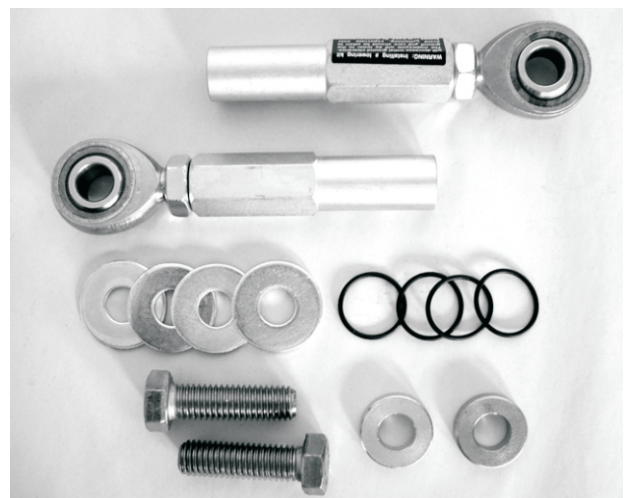

PART NUMBER

B28-250



INSTALLATION INSTRUCTIONS

- Place your motorcycle securely on a stand, jack, or blocks so the rear wheel is slightly off the ground.

WARNING

Bike MUST be securely supported with the rear wheel slightly off the ground. Failure to securely support the bike could result in injury or death.

- Following an authorized shop manual, remove your shocks. Note the location of all mounting hardware. They will be reused with your Burly Brand Lowering Kit. If any of the OEM components are worn or damaged, they need to be replaced
- To disassemble your shock with a hydraulic press, make a fixture to support the shock body as shown in figure 1. You must leave about 2" of space between the end of the ram and the top of the mount (see figure 1). Press straight down on the mount with the hydraulic ram, it only needs to be compressed about 1/4" to expose the wire ring. Remove the wire ring with a pick (see figure 2) and slowly release the hydraulic pressure. Separate the damper from the shock body and spring. You can also disassemble the shock using Progressive Suspension tool #32-5507. Follow the instructions enclosed with the tool.
- Clamp the damper in a vise with soft jaws across the flat sides of the long eye mount (see figure 3). Loosen the spring plate lock nut with a wrench and spin it a few turns for clearance (see figure 3). Loosen the spring plate a few turns in the same direction. Unscrew the damper shaft from the long eye mount with a wrench. The long eye mount is assembled with a thread-locking agent (loctite) so it may need to be heated with a heat gun before removing.
- Remove the spring plate and jam nut from the stock eye mount. Install these parts on the new adjustable mount. Make sure you have turned the spring plate a few turns past the end of the mount so the damper will seat on the end when it is screwed in.
- Put a drop of red thread-locking agent on the damper threads and screw it into the adjustable mount, making sure it seats against the end of the mount. Torque the damper shaft to 25 to 30 ft./lbs. Rotate the spring plate until it bottoms against the damper shaft and tighten the jam nut against it. This is the lowest preload setting (lightest).
- Install the damper assembly into the spring and spring cover (the smaller ID of the spring points forward on the bike). Assemble using a hydraulic press or the Progressive Suspension tool by reversing the order of disassembly. Make sure the wire ring is seated in the groove before slowly releasing hydraulic pressure.
- After repeating the installation on the other shock, adjust the heim and jam nuts to the shortest overall shock length. Now measure the eye-to eye length and match the measurements so both shocks are the same length. Grease both heim balls with heavy grease or moly-disulfide (re-grease every 3 months).
- Re-install the now adjustable shocks on your bike per an authorized factory manual being sure to torque all fasteners to factory specifications, and noting to install the bolts, washers, O-rings, and spacers into the heim as illustrated (see figure 4) - be careful not to pinch the O-rings. Also remember to apply blue thread-locking agent to the threads of the mounting shoulder bolts, and anti-seize to the shoulders when re-installing. Adjust preload as needed per factory manual.
- Proceed to adjusting instructions.

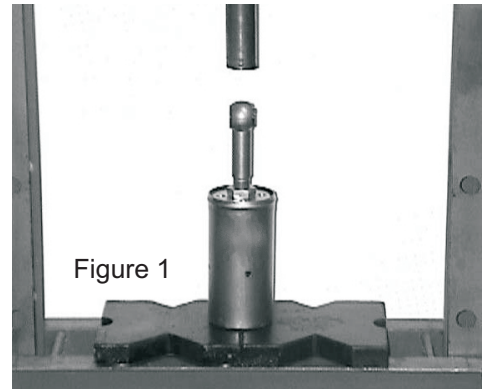

Figure 1

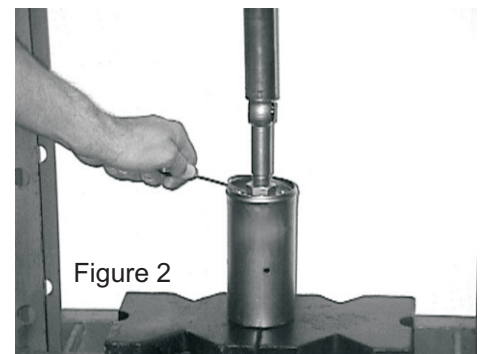

Figure 2

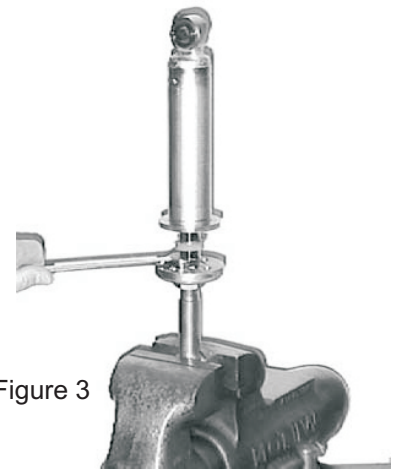

Figure 3

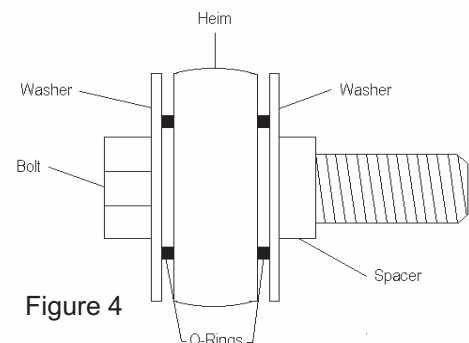

Figure 4



ADJUSTMENT INSTRUCTIONS

The shocks are set at the highest position at this point. Follow these instructions to adjust the seat height lower.

- To lower the ride height, loosen the adjuster jam nut then turn the hex shaft and spring cover clockwise (viewing shock from the rear), lengthening the shocks - thus lowering the bike.
- Turn each shock one hex at a time so the shocks are extend evenly. Do not exceed 2" lower or 1/2" higher than stock setting.
- After adjustment, tighten jam nuts and recheck your installation.
- Once the desired ride height is achieved, it will be necessary to re-adjust the preload. Do this in accordance to your factory manual, noting that it is recommended that the "sag" be set between 1/4 and 1/3 of the remaining wheel travel. For example if you have 2" inches of remaining wheel travel then when you are sitting on the bike, ready to ride, the amount of compression or "sag" should be approximately .50" to .67" inches.
- Raising the ride height is done in the same manner, only the hex shaft is turned in the opposite direction, shortening the shocks - thus raising the bike.