



Installation Instructions

1" Shock Lowering Kit

2005-Later* XL SPORTSTER

WARNINGS & ALERTS

- This kit is designed for Harley-Davidson OEM shocks and OEM tire size only.
DO NOT USE WITH LOWERED SHOCKS!
- This kit is not recommended for the models that are lowered from the factory - **DO NOT INSTALL ON Custom, Low, N or 50th Anniversary MODELS.**
- To maintain proper balanced geometry, we recommend lowering the front and rear of the motorcycle equally. Burly offers fork lowering kits for your motorcycle, too.
- The operator must use extreme caution when operating a modified motorcycle, particularly while familiarizing himself with its altered handling characteristics and reduced ground clearance.
- Check your motorcycle for proper parking lean angle AFTER installation of this kit. Your sidestand may require modification.
- Follow all instructions to achieve proper clearance.
- Enclosed sticker must be applied to a visible area of any motorcycle on which the Burly Brand lowering kit has been installed in order to inform potential riders that the bike has been modified.

TOOLS REQUIRED

- Jack and/or Stand
- 3/4" Wrench
- T50 Torx Socket, & Ratchet
- Ft. / Lb. Torque Wrench
- Thread-locking agent (Loctite® 243)

LIMITED GUARANTEE

We continually inspect and try to improve our products. All parts have been inspected prior to packaging, and our guarantee is limited to replacement of defective parts. This guarantee is in lieu of all guarantees or warranties implied or expressed. Because we cannot control the application of our products, buyer assumes risks for any and all damage caused by himself or third party, by virtue of failure of these parts. We make no warranty as to products distributed by us, expressed or implied, including without limitation any warranties or merchant ability and fitness for a particular purpose. We will however, pass on all warranties made by the manufacturer, who has sole responsibility for performing such warranties. The manufacturer shall solely be responsible for any damage to person or property arising from design, manufacturing and testing of all products, and we accept no liability for such damages. We shall not be liable for indirect or consequential damages.

PARTS INCLUDED

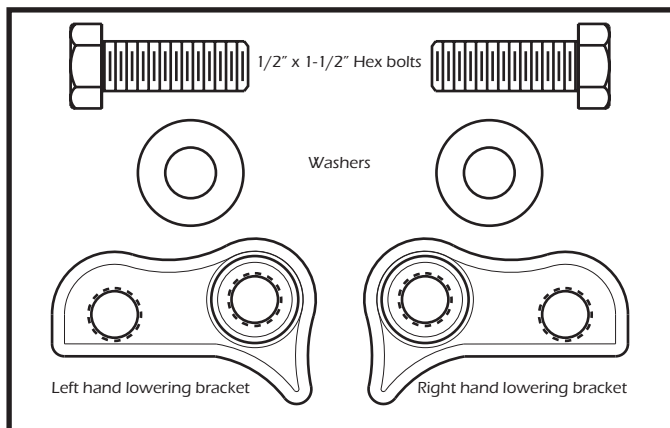

PART NUMBER
B28-52007



INSTALLATION INSTRUCTIONS

- Read all the instructions carefully before installing this kit on your motorcycle. Use your Harley-Davidson manual as a reference while installing this kit.
- Place your motorcycle securely on a stand, jack, or blocks so the rear wheel is slightly off the ground.

WARNING

***Bike MUST be securely supported with the rear wheel slightly off the ground.
Failure to securely support the bike could result in injury or death.***

- Loosen the upper shock bolts. Remove the lower shock bolt and washers. Save these parts as they will be re-used with this kit. If any of the OEM components are worn or damaged, they need to be replaced.
- At this point it is helpful to tilt the shocks up and back then re-tighten the upper shock bolts (Figure 1).
- Using the Thread locking compound and supplied $\frac{1}{2}$ " x 1- $\frac{1}{2}$ " Hex bolts and washers install the lowering brackets to the inside of the swingarm at the shock mount boss (Figure 2).
- Please note that each kit comes with a left and right bracket.
- Loosen the top shock mounts again and lower the motorcycle approximately 1" to align the right shock to the new mount location
- Using the Thread locking compound re-install the stock bolt and washers, but do not fully tighten (Figure 3).
- Repeat procedure on the left side shock.
- Remove motorcycle from the lift and tighten all three bolts to 40 ft/lbs using a torque wrench.
- Check the spring preload on the shocks. Adjustment may be necessary for some people, depending on their weight and ride preference (soft or stiff). Read owners manual for procedure.

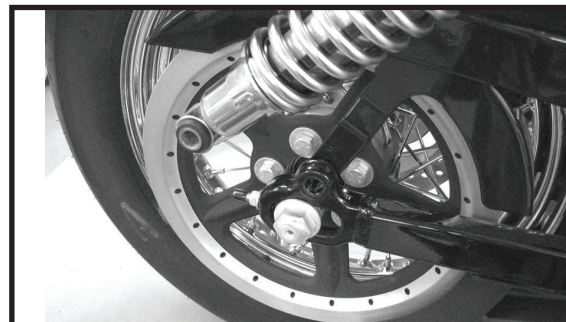

Figure 1

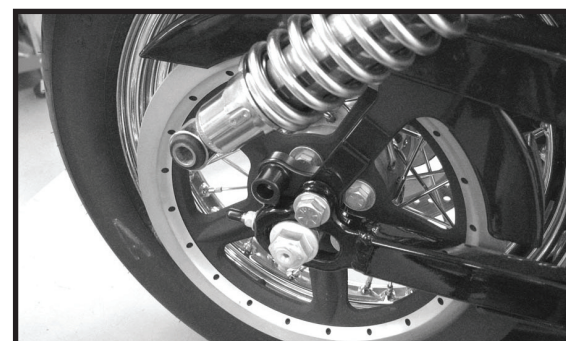

Figure 2



Figure 3